

BASKET FAN

RE-CIRCULATION

HIGHT OUTPUT PERFORMANCE, LOW COST!

Our deluxe Basket Fan series combines high output performance, low cost and maintenance, and energy efficiency to give you one of our best-valued fan series. It provides a high-velocity air pattern with quiet operation.

WHEN APPLIED PROPERLY, SECCO RECIRCULATION FANS CAN BE USED IN THE FOLLOWING APPLICATIONS:

- Air de-stratification reduces heating and cooling bills
- Air exchange when placed in a wall opening or in open sidewall buildings
- Consistent air temperature throughout a room, building- or barn
- Heat stress relief indoors and outdoors for young and adult livestock
- Surface drying (including animal bedding)
- People and animal cooling
- Machine/compressor cooling
- High-velocity air cooling
- Insect control



FEATURES

- Heavy wire with powder coating finishing to prevent corrosion for years
- Airflow design to maximize the efficiency
- Three blades are made with nylon PA66 + fiber reinforcement
- Impeller pitch and motor are closely matched to provide maximum airflow output and the best efficiency
- All stainless steel base and guard
- All top motion motors are designed and rated for years of trouble-free and quiet operation with high efficiency
- Swivel mounting bracket for multiple mounting (ceiling, post, and wall)
- CE and cCSAul certification
- Optional OSHA approved safety guard
- 1-year warranty on all parts

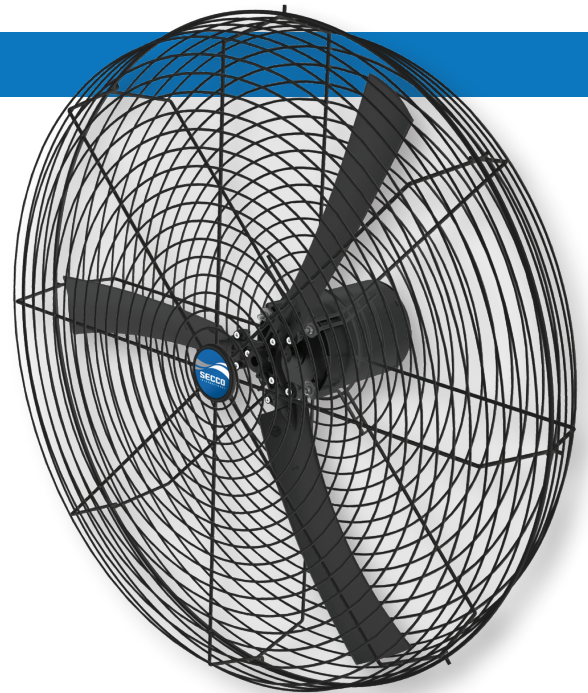

For more information

seccointernational.com



BASKET FAN

RE-CIRCULATION

General Info	Phase	Hz	Volts	Pole	Nominal Blade Size (mm)	Blade Qty	Blade Material	Impeller RPM	Airflow (CFM) [m ³ /h]	Input Power (W)	Amps	Power Factor	FLA	Motor Certification	Thermal Protection
24"	1	50 Hz	230	4	610	3	Nylon	1388	4852 [8243]	489	2.92	0.72	3.01	CE	Yes
		60 Hz	230	4				1645	5345 [9081]	565	2.56	0.95	2.80	cCSAul	Yes
36"	1	50 Hz	220 / 240	6	910	3	Nylon	926	8746 [14 859]	434	1.93	0.97	2.10	CE	Yes
		60 Hz	230	8				843	9252 [15 719]	575	2.82	0.88	3.09	cCSAul	Yes
	3	50 Hz	400	6				924	8821 [14 987]	434	1.24	0.51	1.30	CE	Yes
		60 Hz	230 / 460	8				849	9310 [15 818]	495	1.08	0.57	2.60 / 1.30	cCSAul	No

General info	Frame	Motor Specification	Protection Class	Speed	Ambient Temperature Rating	Nominal Power	Service Factor	Weight (kg)	Guard	Insulation Class	OSHA Protection
24"	NEMA 56	TEAO	IP54	Single	40°C	½HP – 0.375 kW	1.0	18	Steel + Powder Coating	F	Optional
36"	NEMA 56	TEAO	IP54	Single	40°C	½HP – 0.375 kW	1.0	23	Steel + Powder Coating	F	Optional

Other configuration are available.
 The products show in this brochure are covered by a limited warranty.
 Due to our continual effort to provide better products and services; literature, products, performance data and prices may change without notice.

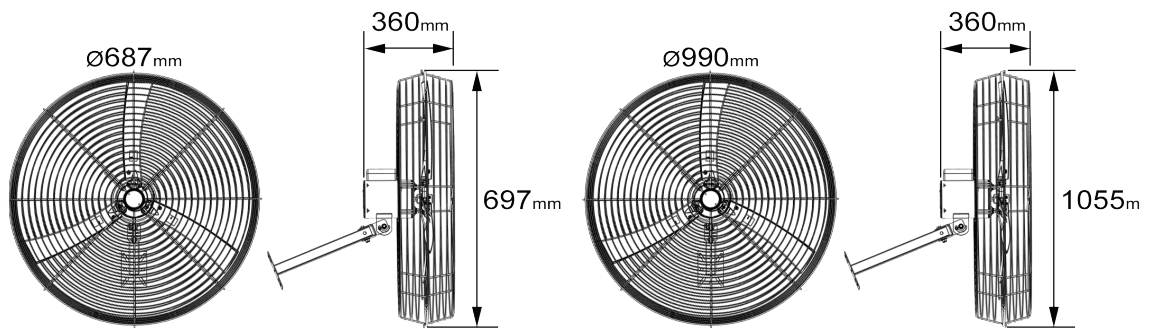

For more information

seccointernational.com

Distributed by:



Secco Europe A/S,
 Division of Secco International, Inc.
 Hedelund 4, Glyngoere, 7870 Roslev, Denmark
 Phone: +45 72 17 55 55
 seccoeurope@seccointernational.com
 www.linkedin.com/company/secco-europe